



FO-KP3

Opel2, Opel2C, Opel3 and Opel3C Rock Retainer Kit

This rock retainer kit will allow you to finish your Opel fireplace with thin non-supporting facing such as tiles. It includes parts to block the top and bottom louver openings, to block only the top louver opening or to let both louvers open. It is not necessary for brick or other self-supporting materials.

Facing materials must be NON-COMBUSTIBLE such as metal, brick, concrete board or ceramic tile. Gypsum board is NOT an acceptable facing material.

❖ WARNING: YOU MUST INSTALL THE CLEAN FACE OPTION (FO-F2 FOR OPEL2/3 OR FO-F3 FOR OPEL2C/3C) ALONG WITH TWO GRAVITY VENT KITS (FO-V2) TO BE ABLE TO COMPLETELY BLOCK OFF ALL LOUVERS.

❖ WARNING: YOU MUST INSTALL TWO GRAVITY VENT KITS (FO-V2) TO BE ABLE TO COMPLETELY BLOCK OFF THE UPPER LOUVER.

INSTALLATION

◆ **NOTE:** We recommend removing the fireplace doors before starting but if you install the rock retainer on an Opel2 or Opel2C, you may want to delay removing the doors in order to make sure to properly align the curved lintel above the doors. Store them in a safe place until the masonry work is finished. Be aware that heavy duty cleaning products or acid solutions will permanently damage plated doors.

◆ **NOTE:** To provide backing for the edges of the rock retainer, the unit must be completely framed.

◆ **NOTE:** A wider steel lintel may be required for heavy rock. If so, contact your local sheet metal contractor for a custom steel lintel and make sure that the final thickness of the masonry allows the doors to open completely. It may be necessary to install the various mesh assemblies farther from the doors. Keep this in mind during the installation.

◆ **NOTE:** Use only the predrilled holes in the FO-KP3 to attach it to the fireplace.

Please start by identifying the configuration of rock retainer you want to install. Figure 1 presents a graphical summary of all the possible configurations:

	Opel2 and Opel2C	Opel3 and Opel3C
Both louvers blocked	Configuration A	Configuration X
Top louver blocked with bottom louver open	Configuration B	Configuration Y
Both louvers open	Configuration C	Configuration Z

Once you have chosen the desired configuration, please make sure to correctly identify the necessary parts as listed in the Figure 2.

Configuration A – Opel2 and Opel2C with both louvers blocked

- A1. If you have already installed the blocking plates from the Clean Face Kit (FO-F2 or FO-F3), remove them. The rock retainer kit provides its own plates.
- A2. Using the self-tapping screws provided, install the top plate assembly (Part 8) over the upper louver opening as shown in Figure 3.
- A3. Take the top mesh assembly (Part 1) and cut off 1 1/8" of both extremities of the curved lintel. This is necessary to be able to install all the parts of the rock retainer kit close to the doors.
- A4. Using the self-tapping screws provided, install the modified top mesh assembly (Part 1) centered (2" out of the side of the fireplace facing) and 3½" above the top of the fireplace facing as shown in Figure 3.

The curved lintel should reproduce the curvature of the doors. Once you have adjusted the curved lintel and screwed it into place, we recommend that you remove the doors. Store them in a safe place until the masonry work is finished. Be aware that heavy duty cleaning products or acid solutions will permanently damage plated doors.

For an Opel2 with the catalytic option (FO-FDCCO) installed, space is required to allow the bypass rod above the door to come through the finishing. For thick finishing material, the rod extension may be required (part of the FO-FDCCO kit).

For an Opel2C, a hole is already made in the mesh for the bypass rod. For thicker finishing material, bypass rod extensions are available (FO-BRE).

- A5. Using the self-tapping screws provided, install the left and right side mesh assemblies (Parts 2 and 3) on each side of the doors, making sure that the edges fit nicely with the arch above as shown in Figure 3.
- A6. Position the bottom louver plate assembly (Part 7) in front of the bottom louver opening to identify where to break off the extremities so that all the lintels align together. Bend back and forth the extremities to break off, no special tooling is required.
- A7. Using the self-tapping screws provided, install the bottom louver plate assembly (Part 7) centered and at 3¼" below the door opening as shown in Figure 3.
- A8. Install the air control plate assembly (Part 9) in the hole of top plate assembly using four self-tapping screws. This removable panel will allow access to the air control if servicing is necessary.

Configuration B – Opel2 and Opel2C with the top louver blocked and the bottom louver open

- B1. Using the self-tapping screws provided, install the top plate assembly (Part 8) over the upper louver opening as shown in Figure 4.
- B2. Using the self-tapping screws provided, install the top mesh assembly (Part 1) centered (2" out of the side of the fireplace facing) and 3½" above the top of the fireplace facing as shown in Figure 4.

The curved lintel should reproduce the curvature of the doors. Once you have adjusted the curved lintel and screwed it into place, we recommend that you remove the doors. Store them in a safe place until the masonry work is finished. Be aware that heavy duty cleaning products or acid solutions will permanently damage plated doors.

For an Opel2 with the catalytic option (FO-FDCCO) installed, space is required to allow the bypass rod above the door to come through the finishing. For thick finishing material, the rod extension may be required (part of the FO-FDCCO kit).

For an Opel2C, a hole is already made in the mesh for the bypass rod. For thicker finishing material, bypass rod extensions are available in 2" length (FO-BRE).

- B3. Using the self-tapping screws provided, install the left and right side mesh assemblies (Parts 2 and 3) on each side of the doors, making sure that the edges fit nicely with the arch above as shown in Figure 4.

Make sure to maintain the 30½" of distance between both side mesh assemblies if you are using the Classic Louvers (FO-OPLC) on your fireplace, otherwise the bottom louver will not fit. It is 30 3/8" wide.

- B4. Using the self-tapping screws provided, install both left and right brackets (Parts 12) as shown in Figure 4.

- B5. Install the air control plate assembly (Part 9) in the hole of top plate assembly using four self-tapping screws. This removable panel will allow access to the air control if servicing is necessary.

Configuration C – Opel2 and Opel2C with both louvers open

- C1. Using the self-tapping screws provided, install the top louver lintels assembly (Part 6) centered on the top louver opening as shown in Figure 5.

- C2. Using the self-tapping screws provided, install the top mesh assembly (Part 1) centered (2" out of the side of the fireplace facing) and 3½" above the top of the fireplace facing as shown in Figure 5.

The curved lintel should reproduce the curvature of the doors. Once you have adjusted the curved lintel and screwed it into place, we recommend that you remove the doors. Store them in a safe place until the masonry work is finished. Be aware that heavy duty cleaning products or acid solutions will permanently damage plated doors.

For an Opel2 with the catalytic option (FO-FDCCO) installed, space is required to allow the bypass rod above the door to come through the finishing. For thick finishing material, the rod extension may be required (part of the FO-FDCCO kit).

For an Opel2C, a hole is already made in the mesh for the bypass rod. For thicker finishing material, bypass rod extensions are available in 2" length (FO-BRE).

- C3. Using the self-tapping screws provided, install the left and right side mesh assemblies (Parts 2 and 3) on each side of the door opening, making sure that the edges fit nicely with the arch above, as shown in Figure 5.

Make sure to maintain the 30½" of distance between both side mesh assemblies if you are using the Classic Louvers (FO-OPLC) on your fireplace, otherwise the bottom louver will not fit. It is 30 3/8" wide.

- C4. Using the self-tapping screws provided, install both left and right brackets (Parts 12) as shown in Figure 5.

Configuration X – Opel3 and Opel3C with both louvers blocked

- X1. If you have already installed the blocking plates from the Clean Face Kit (FO-F2 or FO-F3), remove them. The rock retainer kit provides its own plates.
- X2. Using the self-tapping screws provided, install the top plate assembly (Part 8) over the upper louver opening as shown in Figure 6.
- X3. Take the top mesh assembly (Part 1) and cut off 1" of both extremities of the curved lintel. This is necessary to be able to install all the parts of the rock retainer kit close to the door.
- X4. Using the self-tapping screws provided, install the modified top mesh assembly (Part 1) centered (2" out of the side of the fireplace facing) and 3½" above the top of the fireplace facing as shown in Figure 6. The arch lintel needs to be forced up against the mesh to match the curve of the Opel3 door before being screwed into place

For an Opel3 with the catalytic option (FO-FDCCO) installed, space is required to allow the bypass rod above the door to come through the finishing. For thick finishing material, the rod extension may be required (part of the FO-FDCCO kit).

For an Opel3C, a hole is already made in the mesh for the bypass rod. For thicker finishing material, bypass rod extensions are available in 2" length (FO-BRE).

- X5. Using the self-tapping screws provided, install the left and right side mesh assemblies (Parts 2 and 3) on each side of the door, making sure that the edges fit nicely with the arch above as shown in Figure 6.
- X6. Position the bottom louver plate assembly (Part 7) in front of the bottom louver opening to identify where to bend the extremities so that all the lintels align together. Bend gently once, no special tooling is required.
- X7. Using the self-tapping screws provided, install the bottom louver plate assembly (Part 7) centered and at 3¼" below the door opening as shown in Figure 6.
- X8. Install the air control plate assembly (Part 9) in the hole of top plate assembly using four self-tapping screws. This removable panel will allow access to the air control if servicing is necessary.

Configuration Y – Opel3 and Opel3C with the top louver blocked and the bottom louver open

- Y1. Using the self-tapping screws provided, install the top plate assembly (Part 8) over the upper louver opening as shown in Figure 7.
- Y2. Take the top mesh assembly (Part 1) and cut off 5/8" of both extremities of the curved lintel. This is necessary to be able to install all the parts of the rock retainer kit close to the door.
- Y3. Using the self-tapping screws provided, install the modified top mesh assembly (Part 1) centered (2" out of the side of the fireplace facing) and 3½" above the top of the fireplace facing as shown in Figure 7. The arch lintel needs to be forced up against the mesh to match the curve of the Opel3 door before being screwed into place

For an Opel3 with the catalytic option (FO-FDCCO) installed, space is required to allow the bypass rod above the door to come through the finishing. For thick finishing material, the rod extension may be required (part of the FO-FDCCO kit).

For an Opel3C, a hole is already made in the mesh for the bypass rod. For thicker finishing material, bypass rod extensions are available in 2" length (FO-BRE).

- Y4. Using the self-tapping screws provided, install the left and right side mesh assemblies (Parts 2 and 3) on each side of the door, making sure that the edges fit nicely with the arch above as shown in Figure 7.

Make sure to maintain the 30½" of distance between both side mesh assemblies if you are using the Classic Louvers (FO-OPLC) on your fireplace, otherwise the bottom louver will not fit. It is 30 3/8" wide.

- Y5. Using the self-tapping screws provided, install both left and right brackets (Parts 11) as shown in Figure 7.
- Y6. Install the air control plate assembly (Part 9) in the hole of top plate assembly using four self-tapping screws. This removable panel will allow access to the air control if servicing is necessary.

Configuration Z – Opel3 and Opel3C with both louvers open

- Z1. Using the self-tapping screws provided, install the top louver lintels assembly (Part 6) centered on the top louver opening as shown in Figure 8.
- Z2. Take the top mesh assembly (Part 1) and cut off 5/8" of both extremities of the curved lintel. This is necessary to be able to install all the parts of the rock retainer kit close to the door.
- Z3. Using the self-tapping screws provided, install the modified top mesh assembly (Part 1) centered (2" out of the side of the fireplace facing) and 3½" above the top of the fireplace facing as shown in Figure 8. The arch lintel needs to be forced up against the mesh to match the curve of the Opel3 door before being screwed into place

For an Opel3 with the catalytic option (FO-FDCCO) installed, space is required to allow the bypass rod above the door to come through the finishing. For thick finishing material, the rod extension may be required (part of the FO-FDCCO kit).

For an Opel3C, a hole is already made in the mesh for the bypass rod. For thicker finishing material, bypass rod extensions are available in 2" length (FO-BRE).

- Z4. Using the self-tapping screws provided, install the left and right side mesh assemblies (Parts 2 and 3) on each side of the door opening, making sure that the edges fit nicely with the arch above, as shown in Figure 5.

Make sure to maintain the 30½" of distance between both side mesh assemblies if you are using the Classic Louvers (FO-OPLC) on your fireplace, otherwise the bottom louver will not fit. It is 30 3/8" wide.

- Z5. Using the self-tapping screws provided, install both left and right brackets (Parts 11) as shown in Figure 8.

For all configurations

1. Cover the rest of the wall with wire mesh, or metal lath, overlapping the already installed screen. Make sure nails or staples used for fastening the mesh penetrate the studs by at least 1".
2. Using a plasterer's or mason trowel, apply a scratch coat of mortar that covers the wire mesh and screen. The mortar must be "thin set", or "thin bed" type, inherently polymer modified. If the mortar is not modified, then a synthetic latex additive should be added. Mix to a firm moist consistency. Let the mortar set before adding another coat. This will take several hours. Afterwards, apply a thinner coat and the facing. Do not spread plaster over more than a workable area so that the mortar will not set before the facing is applied. If required, use a grout bag to fill the joints. Take extra care to avoid smearing on the surface of the facing (see Figure 9).

Remember that the air control plate assembly (Part 9) provides access to the air control located behind the right side top louver opening. It is important that the finishing which covers this area should be installed in such a way that it can be removed easily, if necessary, such as one big rock as shown in Figure 10.

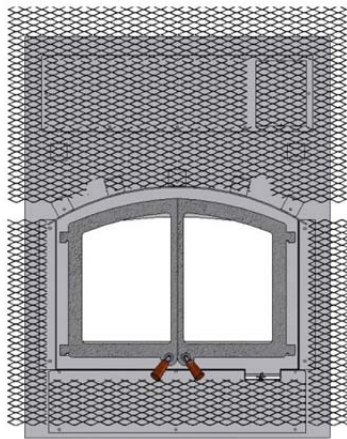

Configuration A

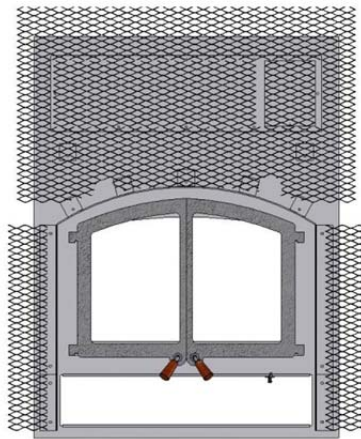

Configuration B

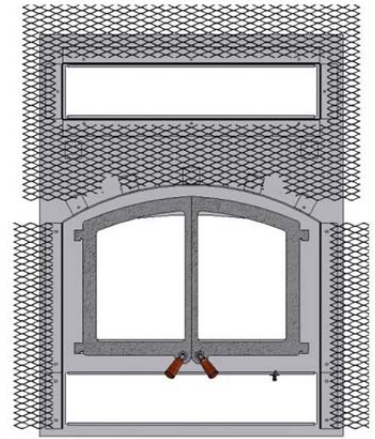

Configuration C

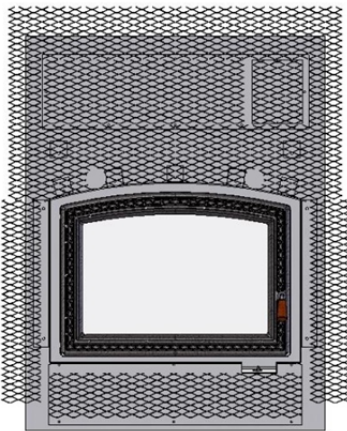

Configuration X

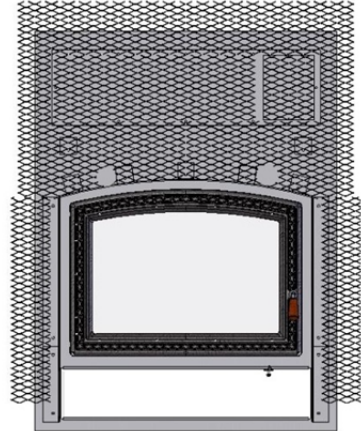

Configuration Y

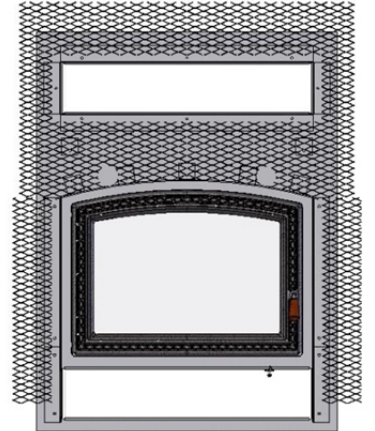

Configuration Z

Figure 1 Toutes les configurations possibles / All possible configurations

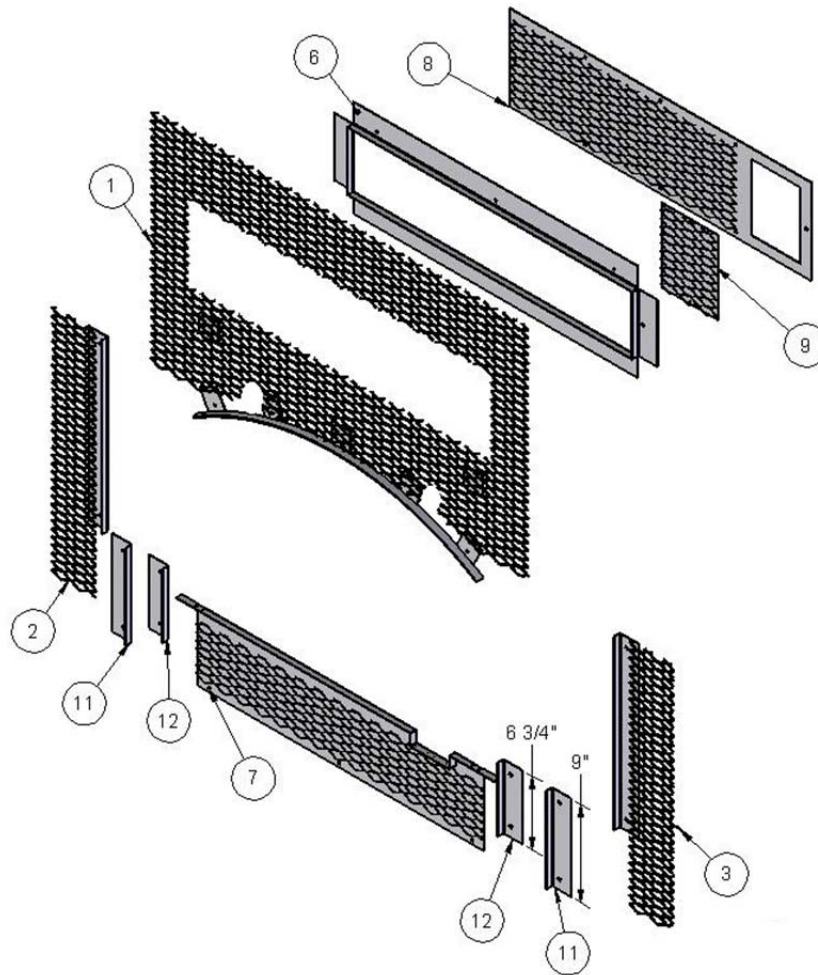

	Configuration					
	A	B	C	X	Y	Z
Pièce/Part 1	✓	✓	✓	✓	✓	✓
Pièce/Part 2	✓	✓	✓	✓	✓	✓
Pièce/Part 3	✓	✓	✓	✓	✓	✓
Pièce/Part 6			✓			✓
Pièce/Part 7	✓			✓		
Pièce/Part 8	✓	✓		✓	✓	
Pièce/Part 9	✓	✓		✓	✓	
Pièce/Part 11					✓✓	✓✓
Pièce/Part 12		✓✓	✓✓			

Figure 2 Liste des pièces par configuration / List of parts per configuration

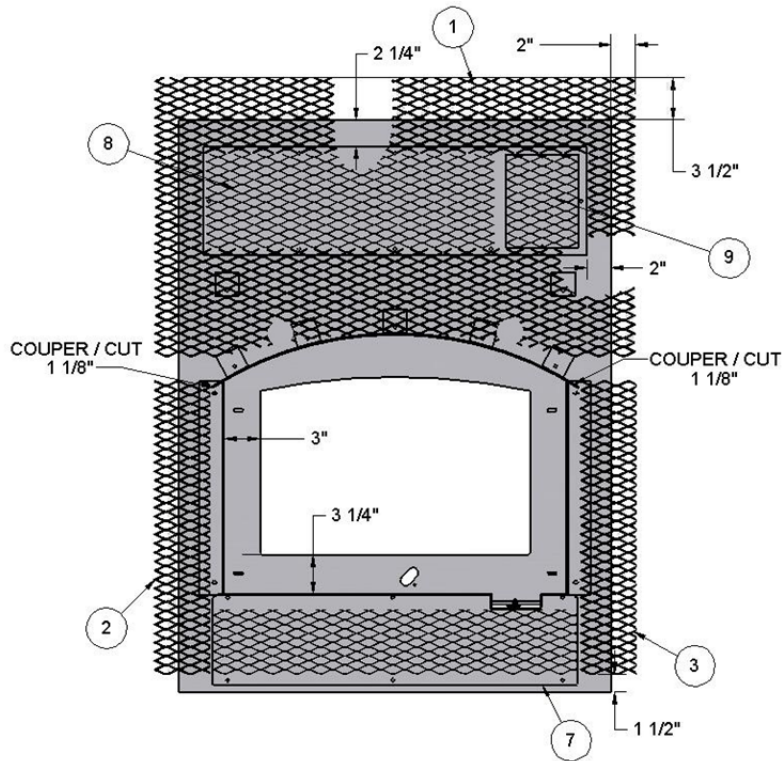

NOTE:

Utilisez seulement les trous préperforés du FO-KP3 pour le fixer sur le foyer.

Use only the predrilled holes in the FO-KP3 to attach it to the fireplace

Figure 3 Configuration A - Installation

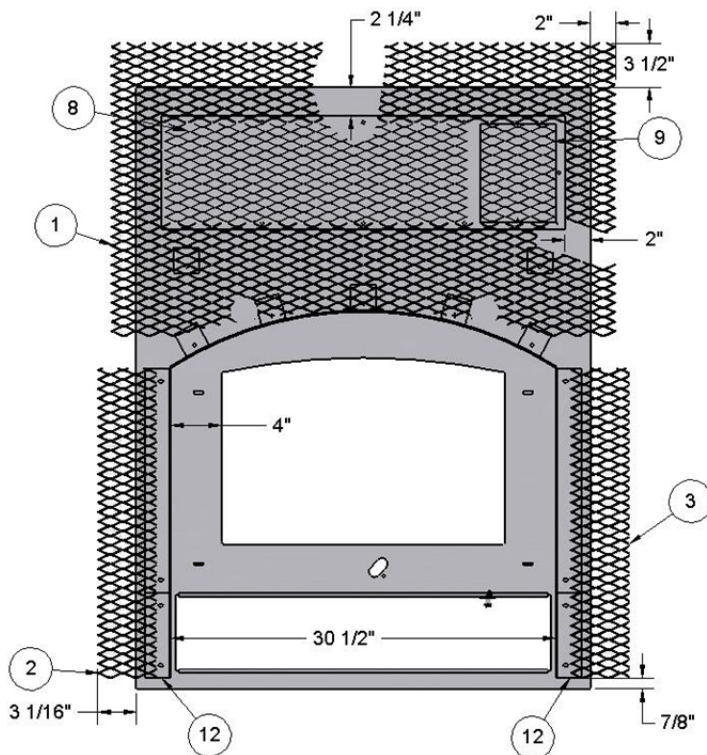

NOTE:

Utilisez seulement les trous préperforés du FO-KP3 pour le fixer sur le foyer.

Use only the predrilled holes in the FO-KP3 to attach it to the fireplace

Figure 4 Configuration B - Installation

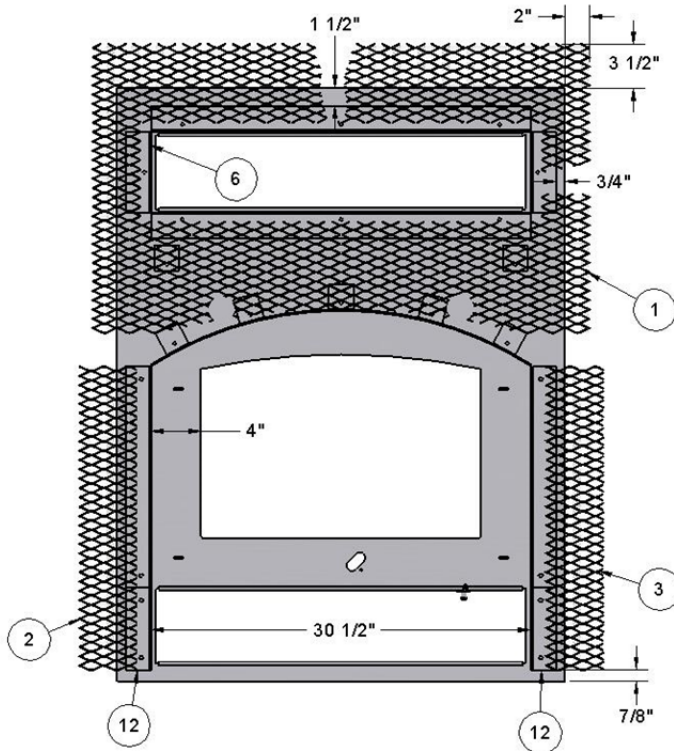

NOTE:

Utilisez seulement les trous préperforés du FO-KP3 pour le fixer sur le foyer.

Use only the predrilled holes in the FO-KP3 to attach it to the fireplace

Figure 5 Configuration C - Installation

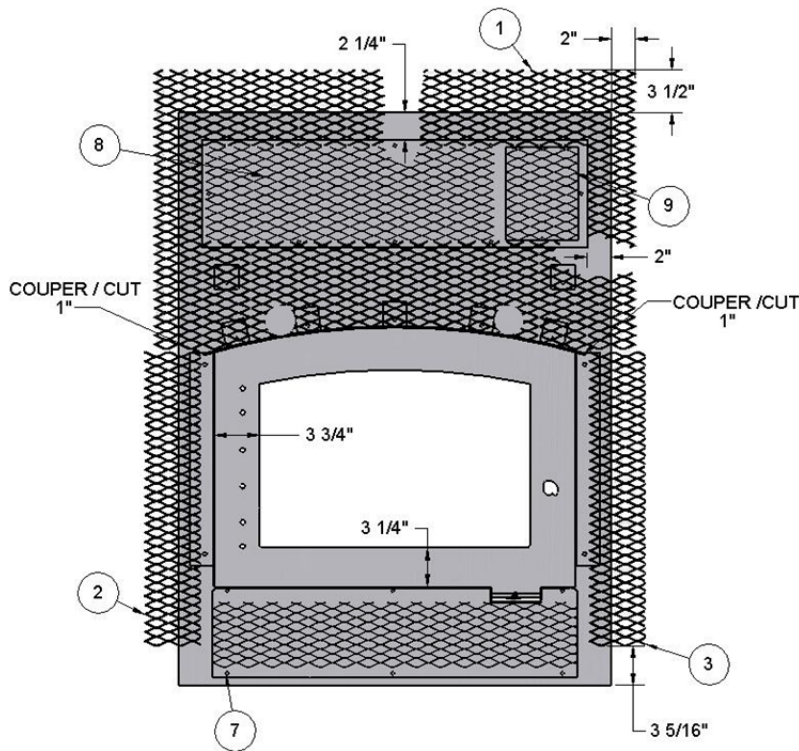

NOTE:

Utilisez seulement les trous préperforés du FO-KP3 pour le fixer sur le foyer.

Use only the predrilled holes in the FO-KP3 to attach it to the fireplace

Figure 6 Configuration X - Installation

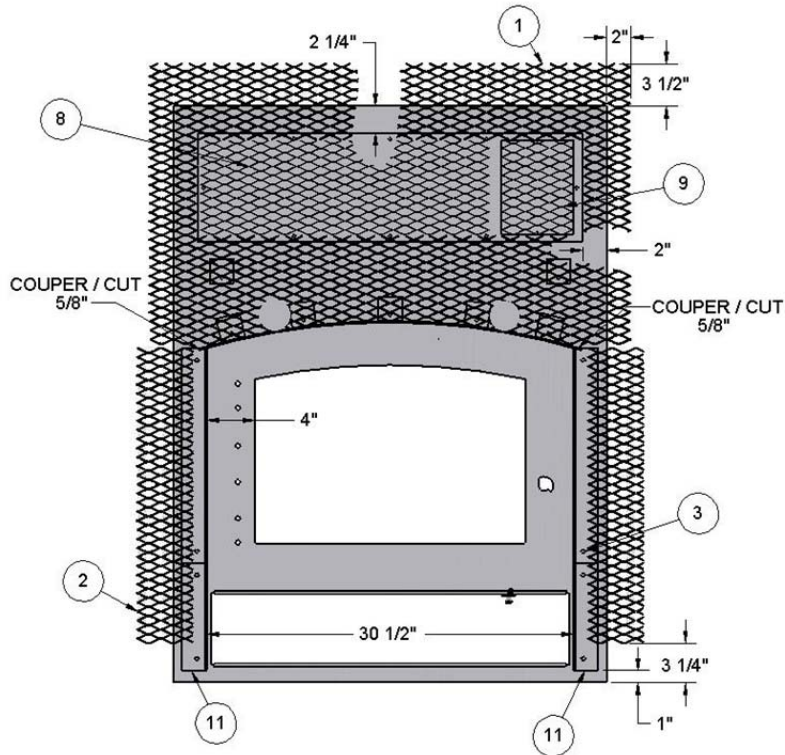

NOTE:

Utilisez seulement les trous préperforés du FO-KP3 pour le fixer sur le foyer.

Use only the predrilled holes in the FO-KP3 to attach it to the fireplace

Figure 7 Configuration Y - Installation

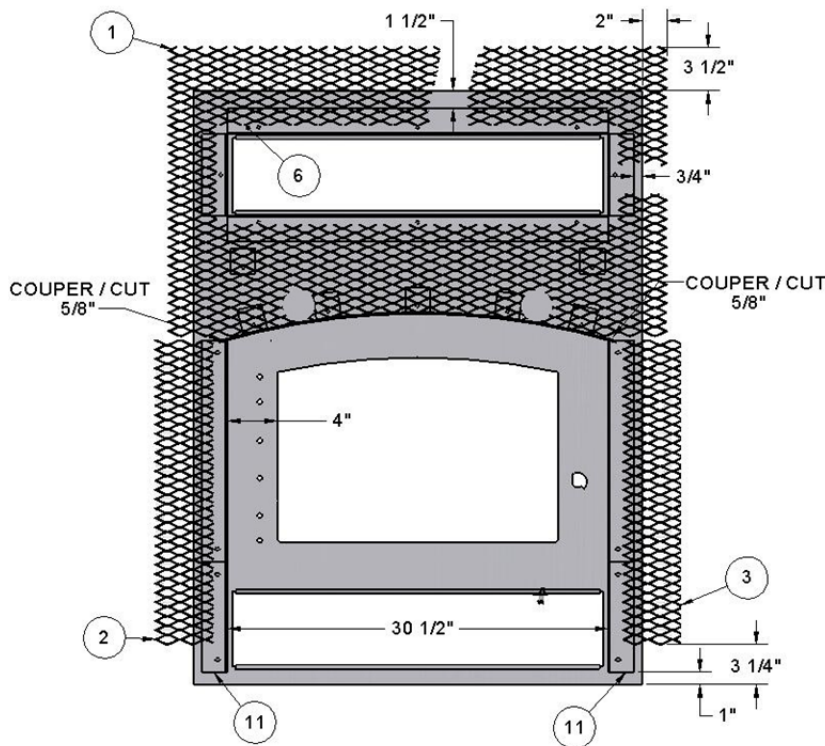

NOTE:

Utilisez seulement les trous préperforés du FO-KP3 pour le fixer sur le foyer.

Use only the predrilled holes in the FO-KP3 to attach it to the fireplace

Figure 8 Configuration Z - Installation

Pierres, carreaux ou briques /
Stones, tiles or bricks

Mortier / Mortar

Trousse de retenue de façade /
Rock retainer kit

Âtre / Hearth

Grillage / Wire mesh

Contreplaqué ou panneau de gypse /
Plywood or gypsum board

Pierres, carreaux ou briques /
Stones, tiles or bricks

Mortier / Mortar

Trousse de retenue de façade /
Rock retainer kit

Âtre / Hearth

Grillage / Wire mesh

Contreplaqué ou panneau de gypse /
Plywood or gypsum board

Figure 9 Détails d'installation des matériaux de finition / Detail installation of finishing materials

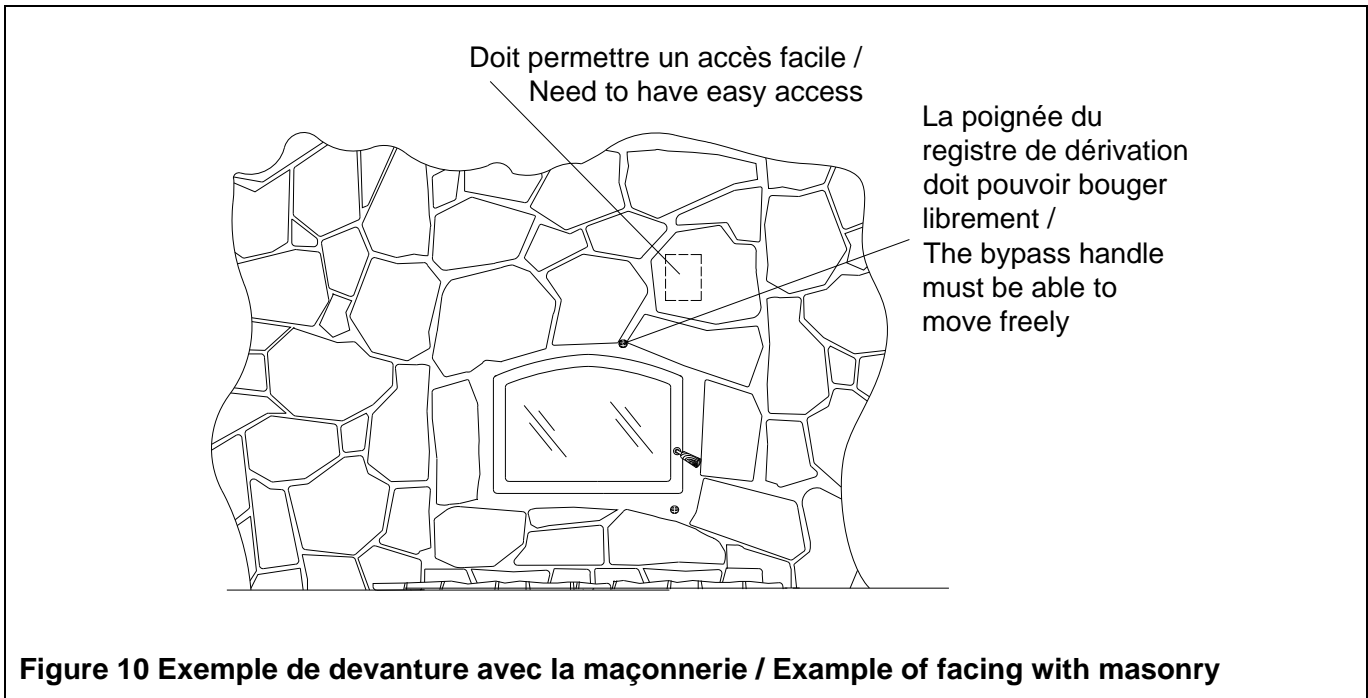

Figure 10 Exemple de devanture avec la maçonnerie / Example of facing with masonry

Liste de contrôle / Check List:

Qté/ Qty	Code	Pièce / Part	Description
<input type="checkbox"/>	1	FO-KP3-A02	(1) Assemblage du grillage supérieur / Superior mesh assembly
<input type="checkbox"/>	1	FO-KP3-A08	(2) Assemblage du grillage côté gauche / Left side mesh assembly
<input type="checkbox"/>	1	FO-KP3-A08	(3) Assemblage du grillage côté droit / Right side mesh assembly
<input type="checkbox"/>	1	FO-KP3-A04	(6) Assemblage des linteaux pour la persienne supérieure / Top louver lintels assembly
<input type="checkbox"/>	1	FO-KP3-A05	(7) Assemblage de la plaque pour la persienne inférieure / Bottom louver plate assembly
<input type="checkbox"/>	1	FO-KP3-A06	(8) Assemblage de la plaque supérieure / Top plate assembly
<input type="checkbox"/>	1	FO-KP3-A07	(9) Assemblage de la plaque pour contrôle d'air / Air control plate assembly
<input type="checkbox"/>	2	FO-KP3-D16	(11) Support inférieur gauche et droit Opel3 / Opel3 left and right bracket
<input type="checkbox"/>	2	FO-KP3-D15	(12) Support inférieur gauche et droit Opel2 / Opel2 left and right bracket
<input type="checkbox"/>	1	950009	Sac, plastique, à glissière, 3" x 3" / Plastic bag with a zipper
<input type="checkbox"/>	28	901006	Vis auto-taraudeuse, #12 x 3/4", hex zinc / Self-tapping screw
<input type="checkbox"/>			Notice d'installation et liste de contrôle / Instructions and check list



**INITIALES
INITIALS**